

**RESOLUTION NO. 2017-25**

**A RESOLUTION AUTHORIZING THE FUNDING OF UP TO \$14,474 FOR THE PURCHASE OF 20 STREET TRASH CANS FROM GRABER MANUFACTURING INC**

WHEREAS, the Downtown Community Improvement District (the "District"), which was formed on February 7, 2011, by Ordinance No. 20866 (the "Ordinance") of the City Council of the City of Columbia, Missouri, is a political subdivision of the State of Missouri and is transacting business and exercising powers granted pursuant to the Community Improvement District Act, Sections 67.1401 through 67.1571, RSMo., as amended ("the Act"); and

WHEREAS, 67.1461.1 of the Act grants the board of directors (the "Board of Directors") of the District the authority to possess and exercise all of the District's legislative and executive powers; and WHEREAS, the Board had elected to fund up to \$14,474 for purchasing 20 street trash cans from Graber Manufacturing Inc.

NOW, THEREFORE, BE IT RESOLVED BY THE BOARD OF DIRECTORS OF THE DOWNTOWN COMMUNITY IMPROVEMENT DISTRICT AS FOLLOWS:

1. The Board of Directors hereby approves the funding and the Chairman of the District is authorized to execute, and the Secretary is authorized to attest on behalf of the District, funding of up to \$14,474 to purchase 20 street trash cans from Graber Manufacturing Inc.
2. This resolution shall be in full force and effect from and after its passage by the Board of Directors.

Passed this 11th day of July 2017.

\_\_\_\_\_  
\_\_\_\_\_, Chairman of the Board of  
Directors

(SEAL)  
Attest:

\_\_\_\_\_  
\_\_\_\_\_, Secretary of the Board of Directors



**Graber Manufacturing, Inc.**

1080 Uniek Dr.  
Wauwaukee, WI 53597

Voice: 800-448-7931  
Fax: 608-849-1081



**Acknowledgement**

Sales Order Number: 68016  
Sales Order Date: Jul 11, 2017  
Est. Ship By: Aug 17, 2017  
Page: 1

**To:**  
The District Office  
11 South 10th Street  
Columbia, MO 65203

P 573-442-6816  
F

**Ship To:**  
City of Columbia-Solid Waste  
C/O Dave Sorrell  
5700 Peabody Road  
Columbia, MO 65202

Customer ID	PO Number	Sales Rep Name	Cust Service Name
DSTRCT	Katie	Andrea Clausen	Andrea Clausen
Customer Contact	Shipping Method	Payment Terms	
	FedEx Economy	Net 30 Days Credit Card Fee 2.6% after shipment	

Qty	Item	Description	Unit Price	Amount
20	CRTR-36F-P	Carnival Receptacle - Flat Lid - 36 Gal. - e-Steele-BLACK	679.20	13,584.00
	AD 20	Above Includes 20% Discount Katie Essing 573-442-6816		

**WE ARE A SUPPLIER ONLY: As a supplier only, we are not subject to subcontractor terms and conditions. The customer is responsible for completeness accuracy and conformity to their plans and specifications. We will not proceed with orders until all details such as materials, options, colors, etc. are complete and accurate.**

SHIPPING AND HANDLING CHARGES: Shipping charges are estimated and are subject to actual shipping charges incurred at time of shipment

Subtotal	13,584.00
Sales Tax	
Shipping & Handling	890.00
<b>TOTAL ORDER AMOUNT</b> US\$	<b>14,474.00</b>

CURRENT LEAD TIME: \_\_\_\_\_ Current lead time is only an estimate based upon existing production demands and material availability as of the date of this quote. Unless indicated above, shipping charges do not include unloading and placement. Lift gate service is available at an additional charge. Call Before Delivery by the freight company is available at an additional charge. If residential or inside delivery is required, there will be an additional freight charge billed to you after delivery.  
CUSTOMER DELAYS: Customer delays greater than two weeks after notification that the goods are ready to ship will incur storage charges at the rate of 1% of the sale amount per day.  
TAXES: Customers are responsible for all taxes. Shipments within Wisconsin that are not tax exempt will be taxed and billed to the customer.  
PRICING: Prices will be held for 90 days. Changes in quantities will effect prices. All prices are in U.S. Dollars.  
CANCELLATION: Orders cancelled more than two weeks after placement are subject to a 30% to 100% charge based upon cost incurred. Custom orders can not be cancelled.  
COMPLETE TERMS AND CONDITIONS: Additional terms and conditions are attached.

*Anne K Essing*  
7-19-17



THOMAS STEELE DIVISION

GRABER MANUFACTURING, INC.

1080 UNIEK DRIVE

WAUNAKEE, WI 53597

P(800) 448-7931, P(608) 849-1080, F(608) 849-1081

WWW.MADRAX.COM, E-MAIL: SALES@MADRAX.COM

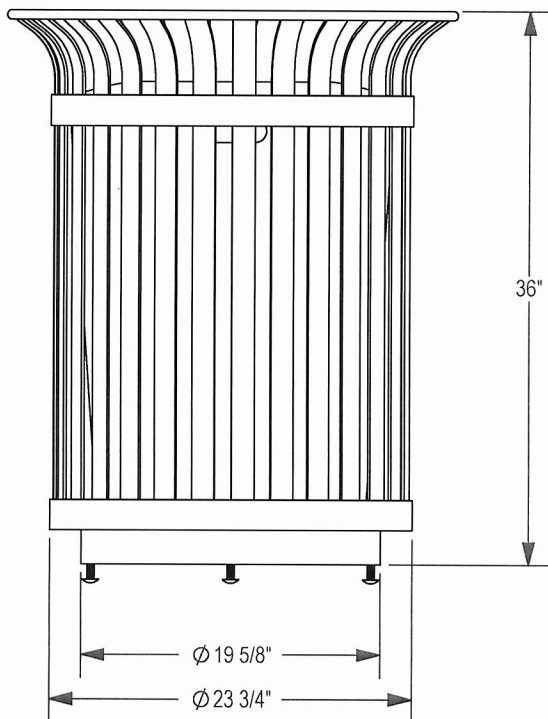
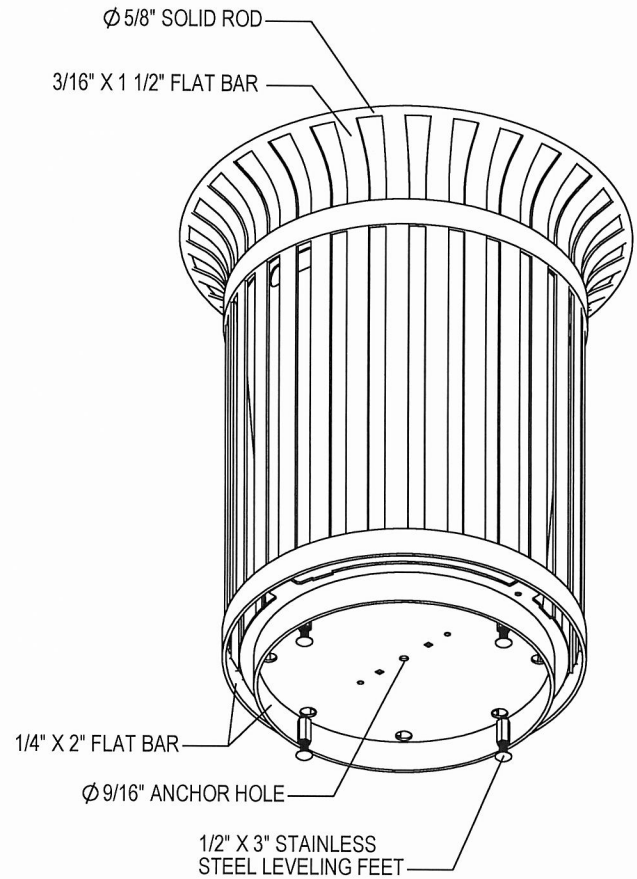
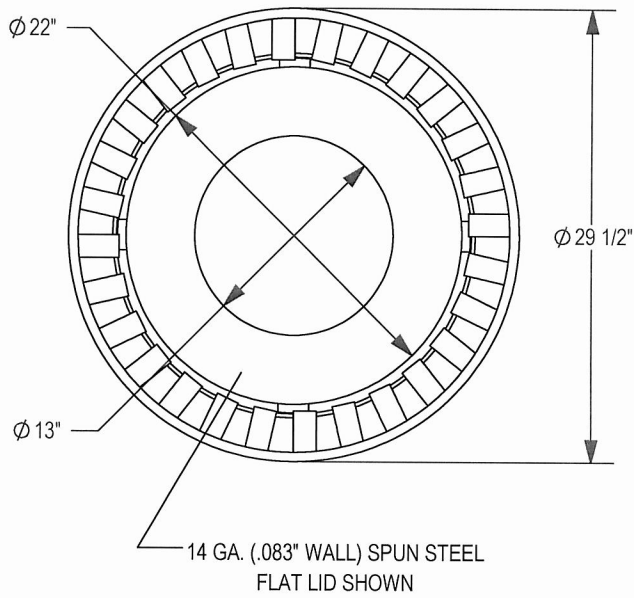

LID OPTIONS



ASH DOME LID



DOME LID



FLAT LID

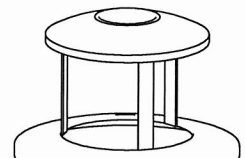

ELEVATED ASH LID

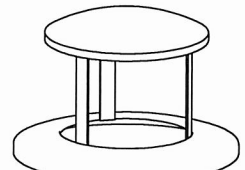

ELEVATED LID



RECYCLE FLAT LID

TRASH LIDS ARE ATTACHED WITH 2 EA. STEEL

VINYL COATED AIRCRAFT CABLE.

PLASTIC LINER INCLUDED.

ALL FASTENERS ARE STAINLESS STEEL

SITE FURNISHING IS POWDER COATED WITH TGIC POLYESTER. STEEL SURFACE PREP INCLUDES MECHANICAL AND CHEMICAL ETCHING FOLLOWED WITH A COATING TO IMPROVE ADHESION AND CORROSION RESISTANCE.

PRODUCT: CRTR-36  
DESCRIPTION: CARNIVAL TRASH RECEPTACLE 36 GAL.

DATE: 5-19-15  
ENG: SMC

CONFIDENTIAL DRAWING AND INFORMATION IS NOT TO BE COPIED OR DISCLOSED TO OTHERS WITHOUT THE CONSENT OF GRABER MANUFACTURING, INC. SPECIFICATIONS ARE SUBJECT TO CHANGE WITHOUT NOTICE.

©2015 GRABER MANUFACTURING, INC. ALL PROPRIETARY RIGHTS RESERVED.

# SHIPPING INFORMATION FOR STANDARD LTL (8ft of Trailer) (updated 2/19/2016)

Thank you for your order. Your Purchase will be delivered via Common Carrier. The driver will bring the freight only to the back of the truck. You are responsible for offloading the merchandise delivered. **A fork lift may be needed.**

**Please note that for all Canadian shipments Graber Manufacturing, Inc. does not provide a broker. A broker is needed for all Canadian shipments and is the responsibility of the customer to provide this information at the time of placing the order.**

**Additional charges will apply for the following.**

- 1) **Lift-gate delivery** - recommended for heavier or larger shipments where no loading dock is available. Approximate additional \$123.
- 2) **Inside delivery** - recommended in cases when you do not have a person available to offload your product and bring them inside your business. Approximate additional \$120.
- 3) **Residential/limited access delivery** - recommended for shipment to a home address, or an apartment or other locations with limited shipping access. Approximate additional \$25.
- 4) **Call before delivery** - the carrier will call 24 to 48 hours prior to delivery. Please provide a name and phone number. Approximate additional \$25.
- 5) **Additional attempts to deliver.** Approximate additional \$120.

Please let Graber Manufacturing know if you will need any of the additional items listed above before your order ships to avoid complications.

Your shipment will leave our docks in good condition. All shipments are insured against damage in transit. If your shipment shows any sign of damage, it should be noted on the freight bill and signed by the driver. You can also refuse delivery of the shipment due to damage. If damage is concealed and not visible until opening, please keep all packaging and notify Graber Manufacturing, Inc. immediately.

## SHIPPING INFORMATION FOR VOLUME/TRUCK LOAD/CONTAINER SHIPMENTS (Over 8ft of Trailer)

The carrier will not move anything to the back of the truck. A forklift and pallet jack will be needed on site or the use of ropes/chains to pull the items to the back of the truck.

If any of this information is a requirement, please advise. Rates may change.

Different provisions may apply.

## ***TERMS AND CONDITIONS***

**WE ARE A SUPPLIER ONLY:** As a supplier only, we are not subject to subcontractor terms and conditions. The customer is responsible for completeness, accuracy and conformity to their plans and specifications. We will not proceed with orders until all details such as materials, options, colors, etc. are complete and accurate.

**ORDER ACCEPTANCE:** All orders must be in writing and are subject to acceptance by Graber Manufacturing, Inc. (Graber Manufacturing) Waunakee, Wisconsin. No verbal orders will be accepted.

**PURCHASE ORDER TERMS:** All terms and conditions of any purchase order, or other writing, issued by the buyer which are inconsistent with, additional to, or different from the terms and conditions set forth here, are null and void. The signing of any such buyer purchase order by Graber Manufacturing, Inc. only indicates the acknowledgement of order.

**PRICES:** All prices are FOB Graber Manufacturing's factory and are in U.S. dollars unless otherwise indicated on quote. Prices are subject to change without notice. Shipments will be made at prices prevailing at the time of the shipment. All out of state (Non-Wisconsin) taxes are the responsibility of the buyer.

**TERMS:** Net is due 30 days from date of invoice when buyer is a tax-supported government entity or a company with approved credit. Buyers without approved credit must submit full payment with order. Service charge is 1-1/2% per month on all invoices after 30 days. Graber Manufacturing also accepts American Express, Master Card and VISA when order is placed (credit card fees of 3% may be assessed if used at other times.) Graber Manufacturing reserves the right to change terms if necessary.

**CANCELLATION:** Cancellation of orders will not be accepted without prior written authorization. Cancellations are subject to a 30% to 100% charge depending on costs incurred by Graber Manufacturing at time of cancellation. Special custom orders cannot be cancelled.

**RETURNS:** Returned product will not be accepted without prior written authorization. A return of standard product is subject to a 30% to 70% restocking charge. Returned product must be received in the same condition as originally shipped and must be shipped with freight charges prepaid by buyer. Special custom product cannot be returned.

**FREIGHT:** Freight charges as determined by the carrier may be prepaid and added to the invoice if desired. Unless specific instructions are given, shipment is made in the way considered best by Graber Manufacturing. Shipping weights are approximate.

**LOSS OR DAMAGE:** Graber Manufacturing is not responsible for loss or damage in transit. Freight carrier is an agent of the customer. Claims must be filed with the carrier. Be sure to note any shortage on the original freight bill before signing and also have the truck driver sign. Be sure to note any damage or marks indicating possible concealed damage on the original freight bill before signing and also have the truck driver sign.

**SPECIFICATIONS:** Graber Manufacturing reserves the right to discontinue or change the design and specification of units, and to ship the revised product without notice when such changes have been made.

**DISCLAIMER OF WARRANTIES:** THERE ARE NO WARRANTIES, EXPRESSED OR IMPLIED, INCLUDING, WITHOUT LIMITATION, WARRANTIES OF MERCHANTABILITY OR FITNESS FOR A PARTICULAR PURPOSE BY GRABER MANUFACTURING. ANY DESCRIPTION OF THE GOODS CONTAINED IN THIS AGREEMENT IS FOR THE SOLE PURPOSE OF IDENTIFYING THE GOODS, IS NOT PART OF THE BASIS OF THE BARGAIN, AND DOES NOT CONSTITUTE A WARRANTY THAT THE GOODS SHALL CONFORM TO THAT DESCRIPTION. NO AFFIRMATION OF FACT OR PROMISE MADE BY THE SELLER, WHETHER OR NOT IN THIS AGREEMENT, SHALL CONSTITUTE A WARRANTY THAT THE GOODS WILL CONFORM TO THE AFFIRMATION OR PROMISE. BUYER AFFIRMS THAT HE HAS NOT RELIED UPON SELLER'S SKILL OR JUDGMENT TO SELECT OR FURNISH GOODS FOR ANY PARTICULAR PURPOSE, AND THIS SALE IS MADE WITHOUT ANY WARRANTY BY SELLER THAT THE GOODS ARE SUITABLE FOR ANY PARTICULAR PURPOSE.

**DIRECTIONS FOR USE:** Due to the potential of misuse of the goods sold under this agreement, it is agreed that our products must be installed as manufactured.

**A. Modifications of Products:** Any modification that becomes necessary must be designed by a qualified engineer and performed in accordance with his design and under the engineer's supervision. Graber Manufacturing cannot be responsible for the structural integrity of the product or for any costs incurred in modifications performed without our written approval.

**B. Errors and Corrections:** Errors in construction and design on the part of Graber Manufacturing must be reported immediately. Graber Manufacturing must be given sufficient time to inspect the product and correct any problem before the products are corrected or installed at the project site. Charge backs will not be accepted for products that are corrected without allowing Graber Manufacturing the opportunity to make the corrections itself or without specific written approval of Graber Manufacturing.

**CONSEQUENTIAL DAMAGES.** IN NO EVENT SHALL THE COMPANY BE LIABLE FOR SPECIAL, INCIDENTAL, CONSEQUENTIAL OR PUNITIVE DAMAGES, INCLUDING, WITHOUT LIMITATION, DAMAGE TO OTHER PROPERTY CAUSED BY ANY DEFECT IN THIS PRODUCT. INCONVENIENCE, LOSS OF GOOD WILL, LOST PROFITS OR REVENUE, LOSS OF USE OF THIS PRODUCT, COST OF SUBSTITUTIVE PRODUCTS OR MODIFICATIONS, DOWNTIME COSTS, OTHER EQUIPMENT COSTS OR CLAIMS OF ANY PARTY DEALING WITH PURCHASER FOR SUCH DAMAGES, RESULTING FROM THE USE OF THIS PRODUCT, OR ANY OTHER LEGAL THEORY.

**AUTHORITY OF SELLER'S AGENTS:** No agent, employee or representative of the Seller has any authority to bind the Seller to any affirmation, representation or warranty concerning the goods sold under this agreement, and unless an affirmation, representation or warranty made by an agent, employee or representative is specifically included within this written agreement, it has not formed a part of the basis of this bargain and shall not in any way be enforceable.

**MODIFICATIONS:** This agreement can be modified or rescinded only by writing signed by both of the parties or by duly authorized agents.

**INTERPRETATION - PAROL EVIDENCE:** This writing is intended by the parties as a final expression of their agreement and is intended also as a complete and exclusive statement of the terms of their agreement. Acceptance or acquiescence in a course of performance rendered under this agreement shall not be relevant to determine the meaning of this agreement even though the accepting or acquiescing party has knowledge of the nature of the performance and opportunity for objection. Whenever a term defined by the Uniform Commercial Code is used in this agreement the definition contained in the code is to control.

**WAIVER:** No claim or right arising out of a breach of this contract can be discharged in whole or in part by a waiver or renunciation of the claim or right unless the waiver or renunciation is supported by consideration and is in writing signed by the aggrieved party.

**TIME FOR BRINGING ACTION:** Any action for breach of this contract must be commenced within 2 years after the cause of action has accrued.

**APPLICABLE LAW:** This agreement shall be governed by Wisconsin Law and the Uniform Commercial Code. Wherever the term "Uniform Commercial Code" is used, it shall be construed as meaning the Uniform Commercial Code as adopted in the State of Wisconsin as effective and in force on the date of this agreement.

**PLACE OF SUIT/VENUE:** Any suit under this contract shall be in the Circuit Court of Dane County, Wisconsin.

**ACCEPTANCE:** Acceptance of this offer must be made on its exact terms and if additional or different terms are proposed by Buyer no contract shall come into existence without offerer's assent to the counteroffer.